

# MINIMAL

## DISPLAY CASE WITH REFRIGERATED SHELF

- + 40% DISPLAY CAPACITY
- + REFRIGERATED SHELF
- + CLASS: 3M2 (-1...+7 °C)
- + HEIGHT-ADJUSTABLE DISPLAY DECK

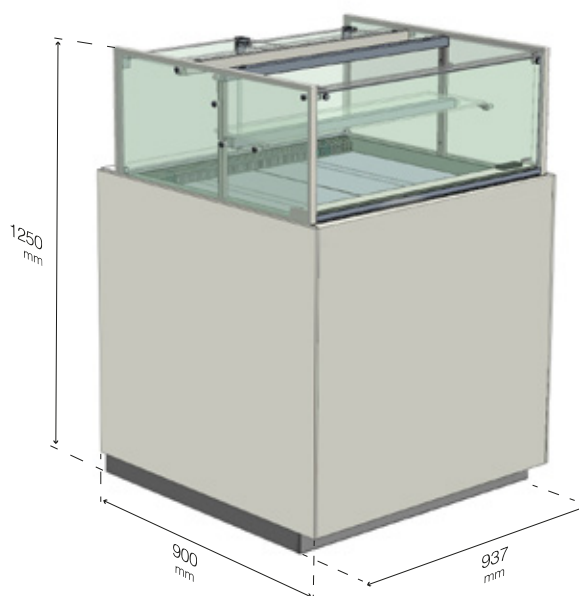

learn more



# MINIMAL

display case with refrigerated shelf

## Sections & Plan view

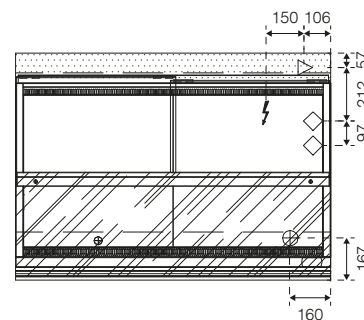
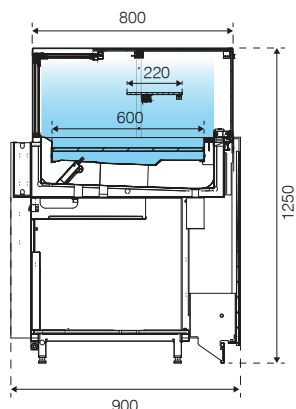

### Key benefits

Elegant and attractive display, suitable for pastry products, drinks, sandwiches, desserts and chocolates.

Model with fully refrigerated glass shelf (3M2), +40% display capacity.

Height-adjustable display deck to adapt the display case to of different products heights.

Sliding rear service doors.

LED lighting which enhances the natural colour of the food.

Internal components easy to remove and clean.

### Technical features

Refrigeration	Ventilated
Climatic Class	3M2 (-1...+7 °C)
Refrigerant	R290
Defrost	Automatic
Electrical supply	230V / 50Hz
Illumination	LED
System	Plug-in / Remote

### Dimensions (mm)

Length	937
Width	900
Height	1250

### Build

Frame	Steel
Interior	Painted
Décor	Painted or other on request
Glass	Double-glazed (end side panels) and pyrolytic (front)

### Optional extra

Service top as Natural Stone or Corian®.  
Display deck in Stainless Steel, Corian® or painted.  
CORK CORE® natural cork thermal insulation.  
J-SMART remote monitoring system.

### Key business areas

Coffee Shops Bakeries Pâtisseries Quick Service Restaurants Chocolate Shops

### Footnotes

**This product is a customised solution, features and specifications need to be confirmed.**

Do not install refrigerated models in environments at temperatures above 25 °C and relative humidity over 60%, unless specified.  
Position equipment away from heat sources such as radiators, heaters, AC units, etc... And never to direct sunlight.



www.jordao.com

**JORDAO**